

# A New Approach to Flow Network Analysis of an Engine Lubrication System

**Reza Soltani\***  
r\_soltani@ip-co.com

**Jafar Ghorbanian**  
j\_ghorbanian@ip-co.com

Tribology Group, CAE Department,  
Irankhodro Powertrain Company

---

Corresponding Author\*  
Received: Dec. 12, 2009  
Accepted in Revised form: Feb. 14, 2010

## Abstract

In order to develop more efficient engines, it is essential to optimize the lubrication circuit of the power train systems. In this paper, during an engine design and development process, a network analysis of the engine lubrication system is described in detail. Two elements have been added to the lubrication circuit in the modified engine. These elements are hydraulic lifters and an Anti-drain valve. The effect of adding and changing the mentioned elements and increasing the bearing clearance has been investigated on oil pump capacity. Also, chain tensioner and anti-drain valve as two new important components in the lubrication system have been investigated as well as other components from tribological point of view. Improving chain tensioner material from Nitrile Butyl Rubber to Poly-Amid and changing the oil jet hole position and diameter, reduce the intensity of wear to the standard level without significant decreasing of main gallery pressure. Adding an anti-drain valve near hydraulic lifter gallery decreases the time which oil needs to reach lifters with sufficient pressure at engine startup. The analyses are done by Flowmaster7.6 and AVL-EXCITE7.02 software and an accessory code. Finally, theoretical results are validated by a completely controlled lubrication functional test.

**Keywords:** *Lubrication Circuit, Bearing Map, Chain Tensioner, Flowmaster, Journal Bearings*

## Introduction

Modern engines are being designed to operate at high engine speeds and loads. In order to fulfill the requirements of developing new engines, lubrication system must be improved. Up to now, some methods have been developed by several researchers. Robert S. LO [1], in 1971, developed an analytical method of simulating an automotive engine lubrication system. This analytical method was used to determine the adequacy of oil pump capacity, evaluating bearing design and oil path circuit. Neu and Wade [2], in 1977, represented the entire engine lubrication system by a series-parallel network of flow passages and flow elements. The pressure distribution and flow rates in the network were computed according to pressure-flow characteristics of each element. Hass and Esch [3], in 1991, presented an overview of the influences of various oil pump parameters as oil pump suction port, rotor geometry and oil pump component clearances on the engine's operating behavior. Mian [4], in 1997, introduced design methods and strategies for pump sizing and flow balance, applicable to a variety of engine classes. Also, he gave mathematical models for oil flows through piston cooling jets, plain journal bearings and plain bearings with a single oil hole feed. S.M. Chun et al. [5, 6], in 2000, developed a computer model to allow for parametric studies of engine lubrication systems. They investigated the effects of various aeration ratios on flow rate and pressure. Felix Klingebiel and Uwe Kahlstorf [7], in 2000, proposed the use of 1-D fluid flow models to predict the engine lubrication system behavior. They used the FLOWMASTER2 program for building 1-D Fluid Flow Simulation Models in an easy manner via a graphical user interface. S.M. Chun [8], in 2003, focused on the flow model through camshaft bearings and hydraulic tappets as well as periodical flow through an oil jet on the big end of the connecting rod. Also, the pressure resistance and pressure gain as the lubricant approaches and leaves the oil drillings on the crankshaft and camshaft were considered. Yiqing Yuan et al. [9], in 2007, established a methodology for predicting lubrication flow in the rod bearings and oil circuits that can be used to guide engineering designs. Yaguo Lu et al. [10], in 2009, developed a software for simulating aero-engine lubrication system.

In this paper, two important components, chain tensioner and anti-drain valve, have been investigated as well as other components in the lubrication system. The analysis

of these elements with other components in a lubrication circuit was not discussed in previous works. The results of these changes have been analyzed during a design process from a tribological point of view. For more accurate results, bearings are analyzed in AVL-EXCITE software and an accessory code is developed for making bearing oil flow map and linked to Flowmaster which has not been done yet. In AVL-EXCITE software, bearing oil flow rate due to shaft rotation, displacement and oil feed pressure for all main and pin bearings have been calculated precisely. The accessory code also used to convert the results of bearing analyses as input was data to the known format data of Flowmaster software.

## Engine description

There are three important reasons for improving the base engine to the modified engine: (1) using inexpensive and locally abundant CNG fuel, (2) demanding higher power and (3) modifying weaknesses of the base engine. The engine parameters are listed in table 1.

## Lubrication functional test

This test is applicable to Diesel and Gasoline engines. It is intended that this test is carried out at an early stage of development on a standard test bed on a fired engine. The engine must have a development status as a requirement for this test. The test was planned to be carried out on a maximum clearance engine but in the case of minor modifications to an existing engine concept the tests can also be carried on a normally build engine.

After installing the sensors in particular locations of lubrication circuit like the main gallery, oil pump outlet, oil filter inlet and outlet, the end side of the hydraulic lifter gallery, the engine is configured on the dynamometer and prepared for lubrication functional test. This test is divided into steady state and transient parts. In the steady state part the oil temperature is fixed at 90 and 130 °C and for each temperature engine speed is swept from idle to rated speed and data acquisition is performed for each point. Consequently, oil pump flow rate and oil pressure at the mentioned points are measured and essential characteristic curves can be extracted. In the transient part, on the other hand, the time of delivering oil to different elements in the lubrication circuit is measured. Finally, the results of the simulation can be compared and validated with experimental test. A view of lubrication functional test cell and its equipment is shown in Figure 1.

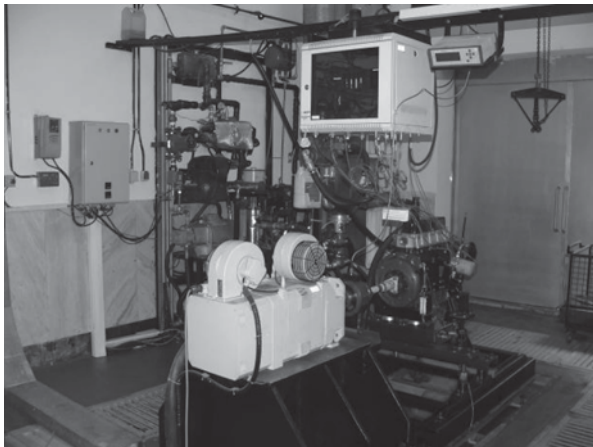

**Fig 1.** A view of lubrication functional test cell and its equipment

**Table 1.** Comparison between base and modified engines

Engine Characteristic	Base Engine	Modified Engine
Fuel type	Petrol	CNG-Petrol
Displacement (cc)	1596	1698
Compression ratio	9.5	10.8
Lifter type	Mechanical	Hydraulic
Anti drain valve	No	Yes
Piston cooling jet	No	Yes
Chain tensioner	NBR	Poly Amid
Main bearing diameter (mm)	54	50
Main bearing clearance (micron)	20-71	33-84
Pin bearing clearance (micron)	23-61	26-66

**The flowmaster v7.6 program**

The Flowmaster is a one-dimensional fluid flow program based on the theory of stream lines. The physical basis for this program comprises empirical and analytical equations for mass, momentum, and energy plus an extensive database to describe the system parts. In Flowmaster software there are just some simple elements like pipe, bend, etc. creating a new and compound elements like chain tensioner and camshaft bearing need a special knowledge and enough experience. After completing the lubrication circuit in this software, the geometry and characteristics of different elements should be inputted. Some of this input data, for instance, the characteristic curves of the oil pump, oil filter, hydraulic lifters, bearings and anti drain valve are extracted from the lubrication functional test. Also, the geometry of different elements is obtained from benchmarking laboratory.

The Flowmaster uses a linearization technique for the pressure/flow equations and the continuity formulation at the nodes (Figure 2); then a set of equations is formed. For example, in Figure 2, three two-armed components connected to a common node in a network are used to construct the matrix. The linear equations derived for each component are not explicit functions of the mass flow. Therefore, an iterative method is used to solve the matrix.

For the network shown in Figure 2, the following linear mass flow equations can be written at each node:

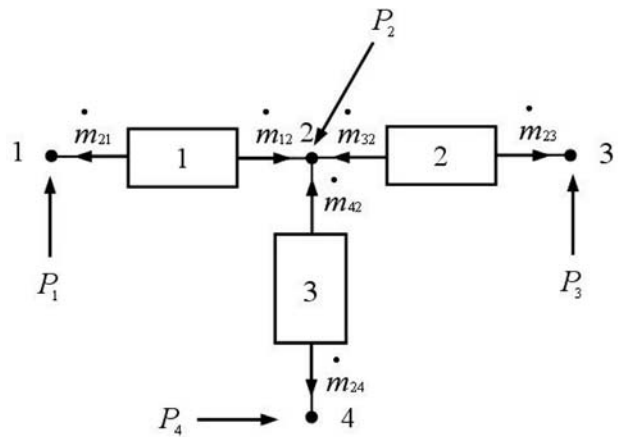

**Fig 2.** Nodes and tracks

$$\begin{bmatrix} a_{21}^1 & a_{22}^1 & 0 & 0 \\ a_{11}^1 & a_{12}^1 + a_{12}^3 + a_{12}^3 a_{11}^2 & a_{11}^2 & a_{11}^3 \\ 0 & a_{22}^2 & a_{21}^2 & 0 \\ 0 & a_{22}^3 & 0 & a_{21}^3 \end{bmatrix} \begin{bmatrix} P_1 \\ P_2 \\ P_3 \\ P_4 \end{bmatrix} = \begin{bmatrix} \dot{m}_{21} - a_{23}^1 \\ \dot{m}_{12} + \dot{m}_{32} + \dot{m}_{42} - a_{13}^1 - a_{13}^2 - a_{13}^3 \\ \dot{m}_{23} - a_{23}^2 \\ \dot{m}_{24} - a_{23}^3 \end{bmatrix} \tag{1}$$

Where:

- $a$  Constant coefficient
- $p$  Oil pressure
- $\dot{m}$  Oil flow rate

Figure 3 shows a schema for improved engine lubrication circuit in the Flowmaster software environment.

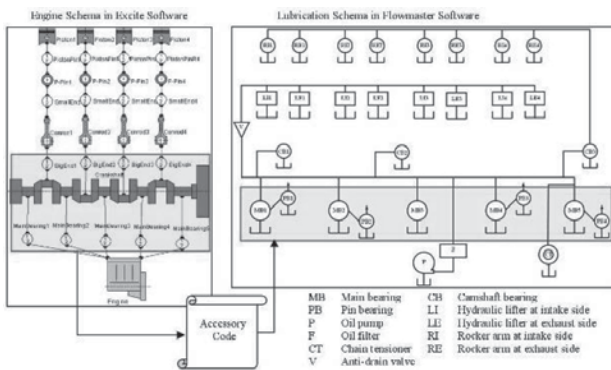

**Fig 3.** schema for improved engine lubrication circuit and connection between AVL-EXCITE software, accessory code and Flowmaster software.

**Bearing calculation**

Bearing calculations are carried out in AVL-EXCITE software by solving the Reynolds equation. For a specified engine, all of the parameters like cylinder pressure, geometry and masses are constant except oil supply pressure, engine speed, oil viscosity and bearing clearance. So, we assumed that the oil flow rate (one of the AVL-EXCITE output results) is a function of the mentioned variables (equation 2) and it is calculated for a wide range of operating points of these parameters. For producing a map of bearing oil flow rate with a specific format, an accessory code is needed which is developed by the authors and explained before in the introduction section.

$$Q = F(n, P_d, C, \mu) \tag{2}$$

Where:

- $Q$  Flow rate through the bearing
- $n$  Rotational speed
- $P_d$  Pressure difference across the bearing
- $C$  Bearing clearance
- $\mu$  Dynamic viscosity of the oil

The Flowmaster can find the needed oil flow rate of bearings by a simple formula and iterative method. Moreover, this allows the user to supply an oil flow rate map for bearings by supplementary software like AVL-EXCITE. As considered above, oil flow rate is an implicit function of pressure, engine speed, viscosity and clearance and oil flow rate cannot be presented to the Flowmaster in a form of equations. Hence, to perform this task the bearing oil flow rate map is used. In addition, in some points that value of  $Q$  is not calculated in oil flow rate map, Flowmaster

can interpolate the value of  $Q$  based on the available data.

It should be noticed that main and pin bearing clearances were increased in the modified engine relative to the base engine. Therefore, the important bearing design parameters should be checked again. One of the most important design parameters in bearing design which should always be verified is minimum oil film thickness. Our calculations in AVL-EXCITE software demonstrate that the value of this parameter for all bearings are in the safe margin and the requirements in accordance with design limitation are covered even in severe conditions. The results are depicted in Figure 4.

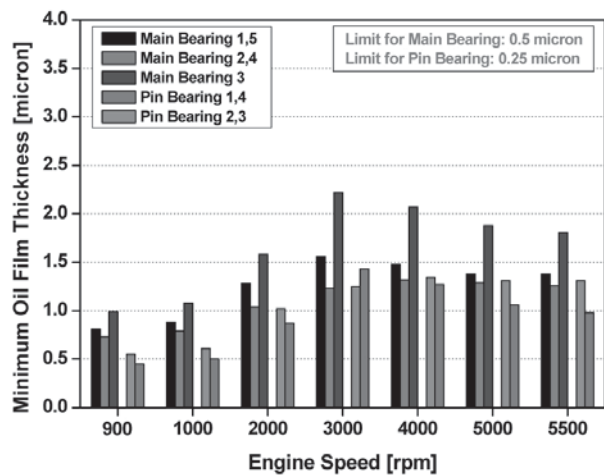

**Fig 4.** Minimum oil film thickness vs. engine speed at 130 for all main and pin bearings

**Chain tensioner**

Chain tensioner comprises a plunger and cylinder which utilize oil to damp the rate of plunger reciprocating motion. In this chain tensioner, a plunger fits slidably into a hollow cylinder to form a high pressure chamber defined by the plunger and the walls of the cylinder. The plunger is urged in the projecting direction by a spring in order to apply tension to a power transmitting chain.

The base engine has a chain tensioner made from NBR (Nitride Butyl Rubber) wearing unacceptably in hard conditions like durability cycles which is shown in Figure 5. Intensive wearing of the original chain tensioner had been frequently reported from after sale market. This defect was also found on the engine standard durability cycles in IPCO's laboratory.

Consequently, the problem was considered in two points of view; improper material and inappropriate lubrication. We concentrated on the lubrication problem by simulat-

ing the chain tensioner in lubrication network and, finally, chose the best position and diameter of oil jet hole which is shown in Figure 6. Besides our effort, the department of design and material chose Poly-Amid in order to improve thermal and wear behavior of chain tensioner. Eventually, in design and development process a chain tensioner for modified engine is developed which is depicted in Figure 6.

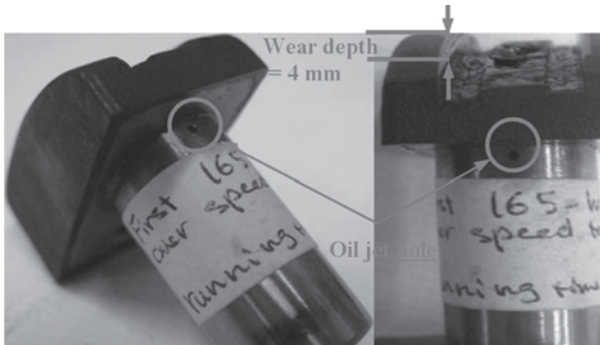

Fig 5. NBR chain tensioner (Original)

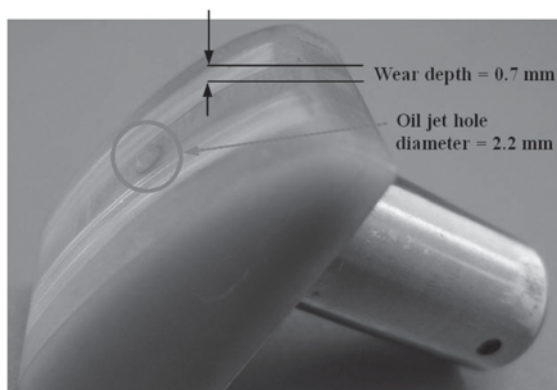

Fig 6. PA6.6 chain tensioner (Modified)

### Hydraulic lifter

The base engine is OHV (Overhead Valve) type and mechanical lifter is used in its valve train system. For in order to improve performance in the modified engine, hydraulic lifter is utilized. By this change in valve train system, all the clearances in the engine valve train system will be adjusted automatically with pressurized oil instead of manual clearance setting in real working engine. Also, the simulation of lubrication circuit indicated that the oil pressure in the hydraulic lifter main gallery is in the proper range. In addition, not only is the wearing rate of valve train mechanism reduced, but also noise and harshness is diminished.

### Anti-drain valve and piston cooling jet

A new element added in the modified engine is an anti-drain valve with a low hydraulic loss. This is used to avoid oil draining from hydraulic lifter gallery due to the gravity when engine is stopped. Adding an anti-drain valve near hydraulic lifter gallery decreases the time which oil needs to reach lifters with sufficient pressure at the engine startup.

Due to the higher power in developed engine, piston temperature raises. Due to temperature control in hot piston surfaces; we had to use piston cooling jets (PCJ). PCJ was also located on connecting rod to spray the oil under piston crown intermittently through the path.

### Analysis of results

#### 1- Validation of Simulation Results

A precise way to evaluate the ability of the Flowmaster in predicting engine lubrication circuit is comparing calculated oil pressure at some important nodes and flow rate of main gallery with the measured ones. It should be noted that the oil type used is SAE 20W50 and the temperature of water and oil fixed at 90 °C for all engine speeds. Figures 7 and 8 show an excellent agreement between experiment and simulation results of the main gallery oil pressure and flow rate respectively.

As it can be seen in figure 7, oil pump relief, valve starts opening at 408 kPa of gauge pressure at 1500 rpm. Also, it is fully opened at 444 kPa of gauge pressure at 2000 rpm. For more validation, the comparison results of oil pressure at some vital nodes like hydraulic lifter, chain tensioner and cylinder head inlet are shown in figures 9, 10 and 11, correspondingly. As shown, the calculated pressures at these nodes trace accurately and match the measured ones for all engine speeds.

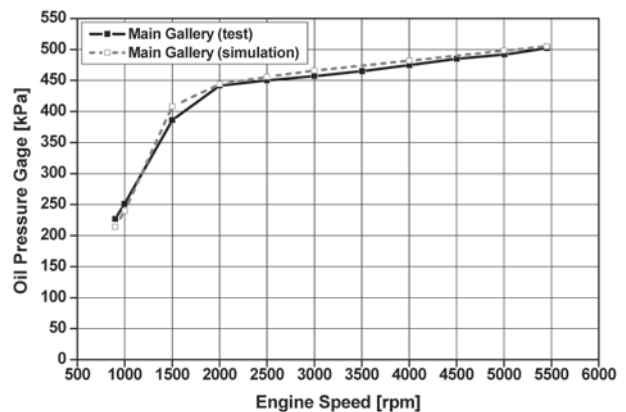
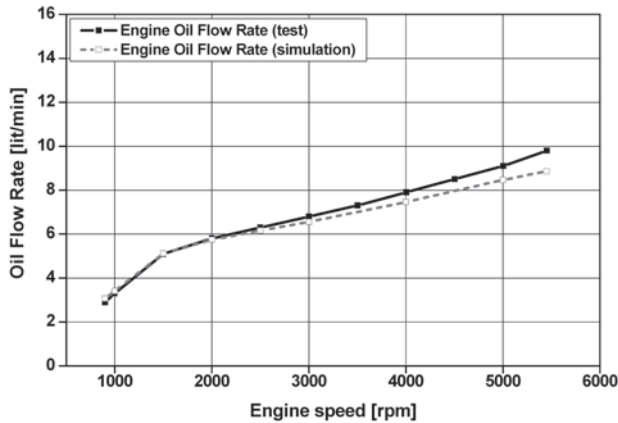
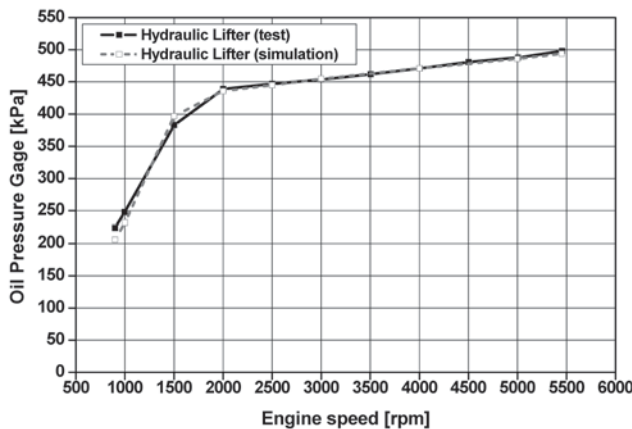

Fig 7. Test and simulation results of main gallery oil pressure vs. engine speed

There is a little pressure difference between the main gallery and the end of hydraulic lifter gallery (comparing figures 9 and 11) due to the following reasons: (1) Hydraulic lifter gallery is very close to the main gallery in the lubrication circuit. (2) Oil flow rate of hydraulic lifters is very low.



**Fig 8.** Test and simulation results of engine oil flow rate vs. engine speed



**Fig 9.** Test and simulation results for oil pressure of hydraulic lifter gallery vs. engine speed

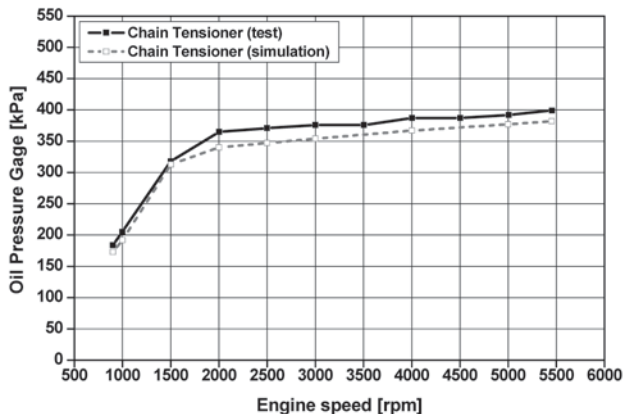

**Fig 10.** Test and simulation results for oil pressure of chain tensioner vs. engine speed

The behavior of the oil pressure in chain tensioner is depicted in Figure 10. It can be seen that the trend of oil pressure in chain tensioner is the same as that of the main gallery.

As rocker arms in OHV type engines need little oil flow rate, the oil pressure in cylinder head inlet is significantly lower than the other points of the lubrication circuit. This is indicated very well in figure 11.

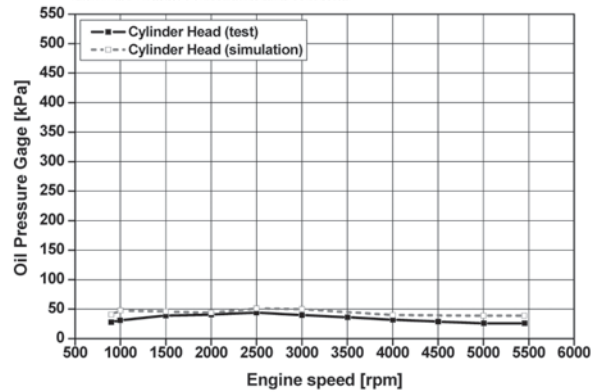

**Fig 11.** Test and simulation results for oil pressure of cylinder head vs. engine speed

## 2- Results of chain tensioner

Chain tensioner is a compound element in lubrication circuit. As considered in section 6 lubrication is one of the most important problems which had to be figured out properly. To solve this problem, oil flow rate in chain tensioner should be increased and oil pressure within chain tensioner ought to be decreased. Since one of the important reasons of high wear rate in chain tensioner is excessive oil pressure. Besides, oil pressure should not be the decreased in vital nodes significantly. Simulation of total circuit is performed in a severe condition called Hot-Idle in which oil temperature is fixed at 130°C and engine speed is equal to 900 rpm. The results show changing of oil jet hole diameter from 1.1 mm to 2.2 mm causes oil flow rate and pressure alter about 9% and -6%, respectively in chain tensioner. Due to the mentioned modification, pressure was reduced around 2% and 4% in the main gallery and the cylinder head consequently (Fig 12). Nevertheless, the lubrication circuit, is still in a safe margin. This means that the new diameter and position not only have no destructive effect on the total circuit, but also reduce the wear of the chain tensioner. Due to this approach and changing chain tensioner material from NBR to PA6.6, the total wearing of the rubber was reduced from 4 mm to below 0.7 mm in depth. This means that wear defect has been removed (comparison between Figures 5 and 6).

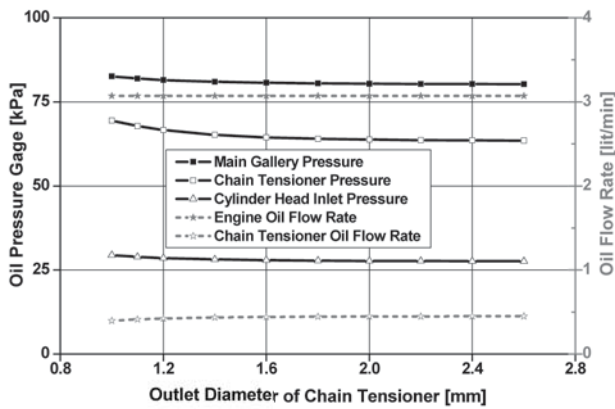

**Fig 12.** Effect of oil jet hole diameter of chain tensioner at hot-idle condition (simulation results)

### 3- Results of Hydraulic Lifter

As mentioned before, during the oil was delivered to the hydraulic lifter at the engine startup should be as low as possible.

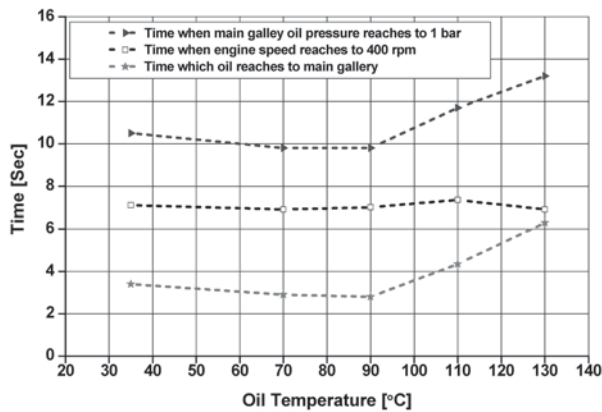

**Fig 13.** Measurement of the oil delivery time vs. main gallery oil temperature at engine startup condition

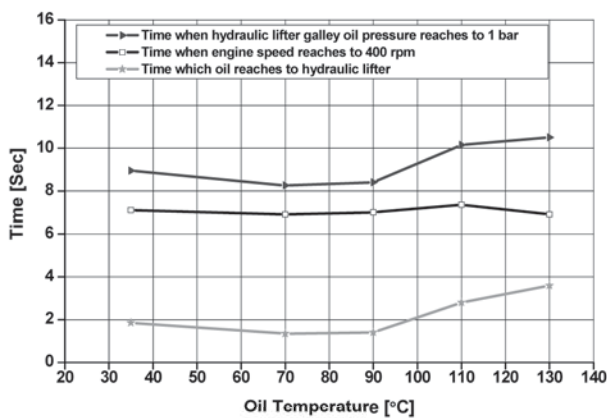

**Fig 14.** Measurement of the oil delivery time vs. hydraulic lifter gallery oil temperature at engine startup condition

As a key issue, an anti drain valve is used in the lubrication system. In the transient part of the lubrication functional test the behavior of oil pressure in main and hydraulic lifter galleries are measured at engine startup which are depicted in Figures 13 and 14, respectively. To obtain this time (oil delivery time) the following two parameters should be measured and subtracted from each other. (1) The time during which oil pressure becomes 1 bar and (2) the time that engine speed reaches 400 rpm (speed of engine startup). As can be noticed in Figures 13 and 14, the effect of different oil temperature on the oil delivery time at engine startup conditions is shown in these figures. When oil temperature rises, the oil viscosity is decreased and the adhesive force between oil molecules and gallery walls is decreased consequently. Due to this fact, the amount of the oil, delivery time reduces, too. As indicated in these figures, the diminishing trend is following up to 90 because of a decrease oil viscosity; nevertheless, when oil temperature reaches over 90 the behavior of this time is completely reversed and, begins to rise. In the second part of the graphs the oil viscosity is decreasing but it dose not have enough pressure and, as a result, the oil delivery time increases.

### 4- Results of Piston Cooling Jet (PCJ)

PCJs are used in real engine and its effect is of that are considered in lubrication functional test but PCJs were crossed out from the lubrication circuit simulation owing to the following reasons: (1) PCJs have intermittent injection behavior; therefore, they include insignificant value of total engine oil flow rate. (2) Transient simulation of PCJs is time-consuming. On the other hand, further calculations indicate that maximum oil flow rate through PCJs is extremely low in contrast with pin bearing oil flow rate. It should be noted that the value of  $Q_{pin\ bearing}$  was estimated at oil temperature of 130 and maximum engine speed conditions and in this state of affairs the contribution of PCJs oil flow rate are calculated in equations 3 and 4.

$$\frac{Q_{PCJ}}{Q_{pin\ bearing}} = \frac{d_{PCJ}}{\pi \times D_{pin\ bearing}} = \frac{10}{\pi \times 45} = \frac{1}{14} \quad (3)$$

$$Q_{PCJs}^{max} = \frac{1}{14} \times Q_{pin\ bearings}^{max} = \frac{1}{14} \times 2.1 = 0.15 [lit/min] \quad (4)$$

Where:

$Q_{PCJ}$  Oil flow rate through a piston cooling jet

$Q_{pin\ bearing}$  Oil flow rate through a pin bearing

$d_{PCJ}$  Piston cooling jet outlet diameter

$D_{pin\ bearing}$  Pin bearing diameter

$Q_{PCJs}^{max}$  Maximum oil flow rate through piston cooling jets

$Q_{pin\ bearings}^{max}$  Maximum oil flow rate through pin bearings

Oil flow rate of each engine component is shown in Figure 15. As it can be considered, PCJs oil flow rate is definitely negligible in comparison with the total engine flow rate. Therefore, it does not have any defect on oil feeding of other components in the lubrication system. Therefore, the accuracy of the simulation without PCJs stays satisfactory.

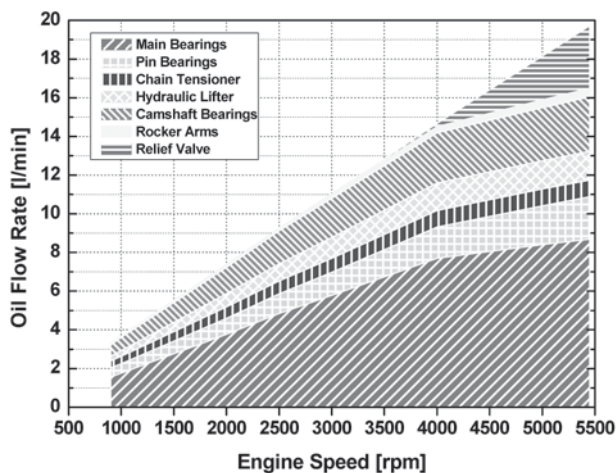

Fig 15. Oil flow rate distribution of engine components at oil temperature of 130°

## 5- Results of Oil Pump

Corresponding to the changes made in the base engine, it should be verified if original oil pump covers the lubrication circuit requirements or not. These changes included: (1) adding hydraulic lifters and PCJs as lubrication system components, (2) increasing chain tensioner oil flow rate (3) increasing main and pin bearing clearances. According to our experience, the minimum value of 12-15% of oil pump flow rate should be passed through relief valve at maximum oil temperature and rated speed. As it can be seen in Figure 15, this value is 16% of oil pump flow rate and the original oil pump can be used in modified engine.

## Conclusion

The aim of this article is introducing a simple and robust methodology to simulate engine lubrication systems during engine design and development process. Also, the effect of adding new elements like chain tensioner and anti-drain valve on oil pump behavior and obligatory minimum pressure in network's vital nodes is verified. Furthermore, changing oil jet hole position and diameter of chain tensioner in modified engine improve the lubrication conditions and the wear intensity reduces consequently. Besides, performing lubrication functional test helped to validate theoretical results of engine lubrication network. The results of the experimental test indicate adding an anti-drain valve in lubrication circuit reduces the oil delivery time to hydraulic lifter gallery with respect to this time in main gallery which is really interesting. In addition, results of simulation show that the PCJs contribution to total oil flow rate is negligible. Therefore, they can be crossed out from the lubrication circuit analysis. As a future work, it will be valuable if the dynamic behavior of oil pump and bearings be simulated at engine start up condition. To simulate this phenomenon, the reaction between air and oil as a two phase flow should be considered.

## References

- [1] Lo R. S., "Digital Simulation of Engine Lubrication Systems", SAE Paper 710205, 1971.
- [2] Neu E. A., Wade J. A. and Chu A. C., "Simulating the Lubrication System of a diesel engine", SAE Paper 770032, 1977.
- [3] Hass A., Esch T., Fahl E., Kreuter P., Pischinger F., "Optimized design of the lubrication system of modern combustion engines", SAE 912407, 1991.
- [4] Mian M., "Design and analysis of engine lubrication system", SAE 970637, p.219-32, 1997.
- [5] Chun, S. M., Park, Y. H., Jang, S., "A study on engine lubrication system by optimized network analysis- part I: case study", SAE 2000-01-2921, 2000.
- [6] Chun S. M., Park Y. H., Jang S., "A study on engine lubrication system by optimized network analysis- part II: parametric study", SAE 2000-01-2923, 2000.
- [7] Felix, K. and Uwe, K., "Simulating Engine Lubrication Systems with 1-D Fluid Flow Models", SAE World Congress in Detroit, Michigan, March 6-9, 2000.
- [8] Chun, S.M., "Network analysis of an engine lubrication system", Tribology International 36-2003, p.609-617
- [9] Yiqing Yuan, Wei Tao, Eysion A. Liu, Gary C. Barber et.al, "Engine lubrication system analysis by considering aeration and cavitation with the rotating oil supply passage", Tribology Transactions; Jan-Mar 2007; 50, 1; ProQuest Science Journals pg. 39.
- [10] Yaguo L., Zhenxia L. and Shengqin H., "Numerical Simulation of Aero-Engine Lubrication System", Journal of Engineering for Gas Turbines and Power, MAY 2009, Vol. 131 / 034503-1.